

Quick connector, bendable – end-to-end



- ▶ For end-to-end connecting of two profiles with equal cross-sections and at any angle, e.g. for frames
- ▶ Profile finishing:
 - blind hole DB11, DB17 or through-hole D11, D17
 - miter cut

Technical data (p. 19-6)

Accessories:

- ▶ Drilling jig (p. 14-2)
- ▶ Cover cap (p. 3-53)

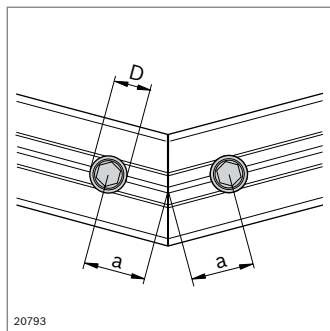

	M_{max} ↓
30x30	24 Nm
40x40L	100 Nm
45x45L	110 Nm
45x45	145 Nm
50x50L	160 Nm

Quick connector, bendable	P1 / P2	a (mm)	D (mm)	ESD		No.
End-to-end	8 / 8	18	11		10	3 842 535 630
	10 / 10	22.5	17		10	3 842 535 634

Material: Tie rod: steel, stainless
Socket: steel; galvanized